

Glenwood™ 170 Post

Installation and Maintenance Instructions

IMPORTANT NOTE: ENSURE THAT ALL RELEVANT PERSONNEL READ THESE INSTRUCTIONS PRIOR TO USE

Please also refer to the 'Manual Handling Operations Regulations 1992' during the handling of the product and materials used for installation. Glasdon recommends that a full Health and Safety analysis is carried out prior to installation.

GLENWOOD 170 POST - EXTENDED BASE MODEL (Concrete-in)

KIT CONTENTS:

ITEM 1 - Glenwood 170 Post

GLENWOOD 170 POST C/W GLENWOOD SOCKET

KIT CONTENTS:

ITEM 1 - Glenwood 170 Post x 1

ITEM 2 - Key Hole Plug x 1

ITEM 3 - Socket Key x 1

ITEM 4 - Glenwood Socket x 1

EQUIPMENT REQUIRED:

- Excavation equipment
- Tape Measure
- Concrete Mix (we suggest using a quick setting concrete i.e. QC10 for all installations)
- Safety Equipment (hard hat, mask, goggles, reflective clothing, etc)

OPTIONAL BLANKING PLATE:

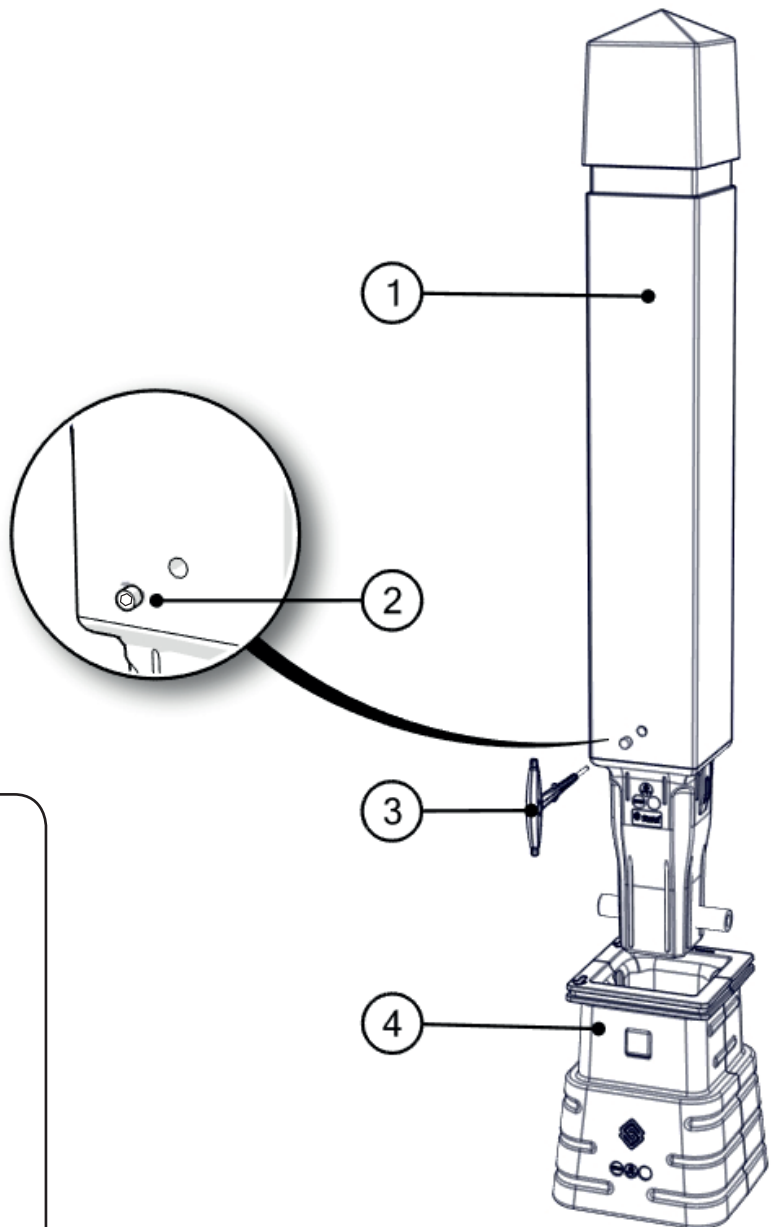
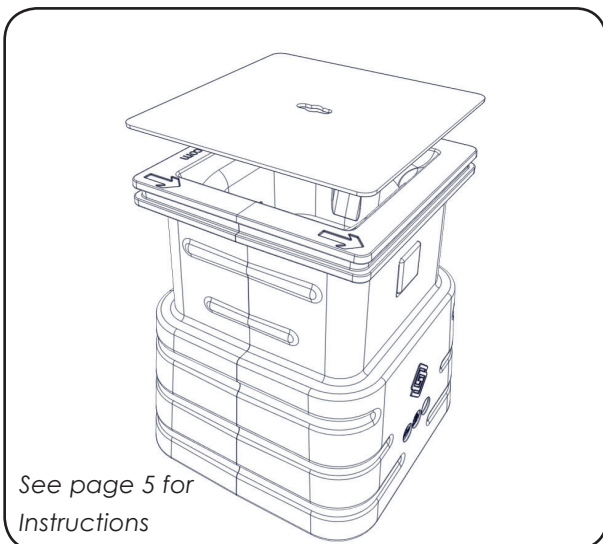
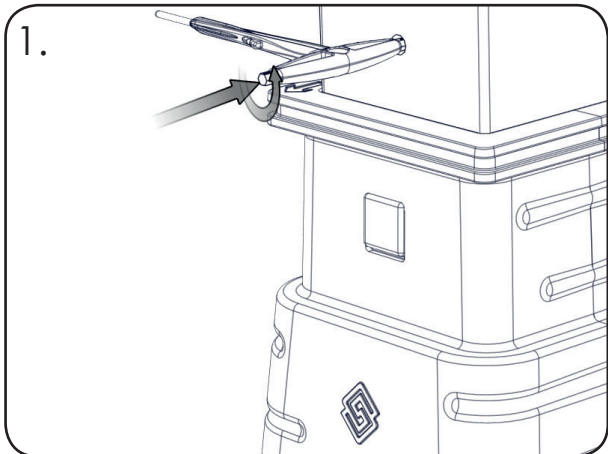

DIAGRAM NOT TO SCALE

GLENWOOD SOCKET SECURITY KEY HOLE PLUG

TO REMOVE:



To remove the key hole plug (Item 2), insert the hexagonal end of the socket key (Item 3) into the hexagonal hole of the key hole plug.

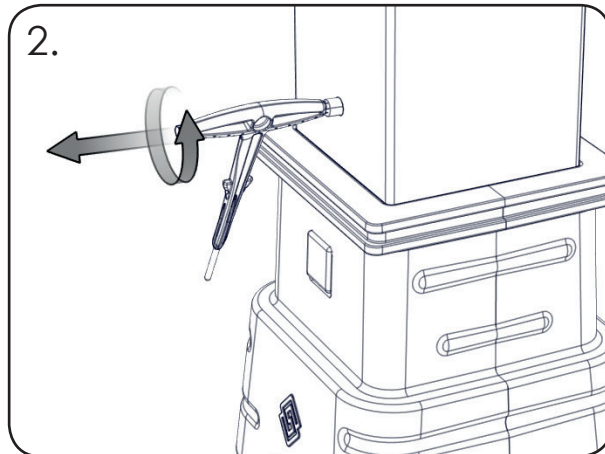

Unscrew the key hole plug by turning anti-clockwise until the plug is removed.

TO INSERT:

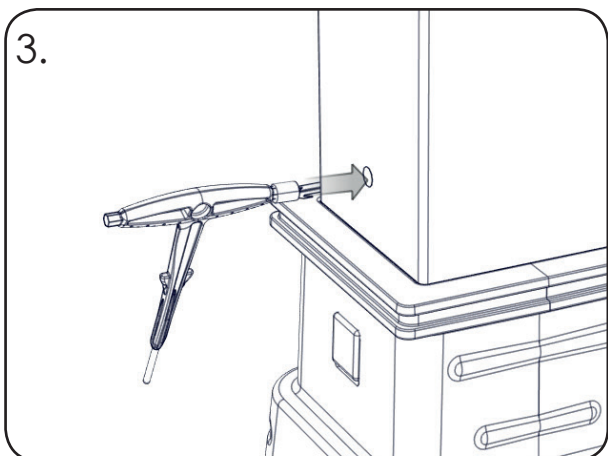

To insert the key hole plug, place on to the hexagonal end of the socket key and place in the hole.

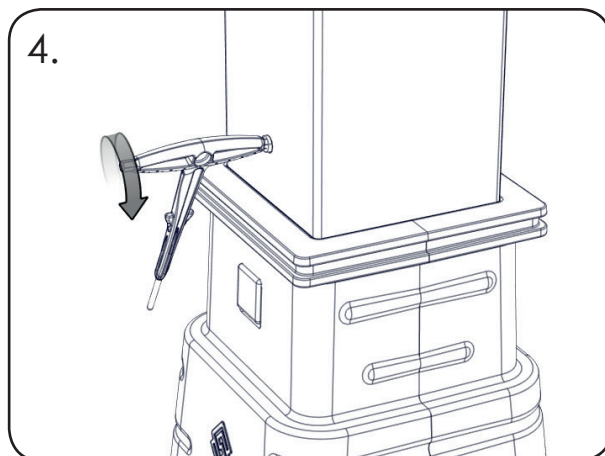

Turn the socket key clockwise until the key hole plug is secure.

GLENWOOD SOCKET INSTALLATION INSTRUCTIONS

See our website for a video guide - www.glasdon.com

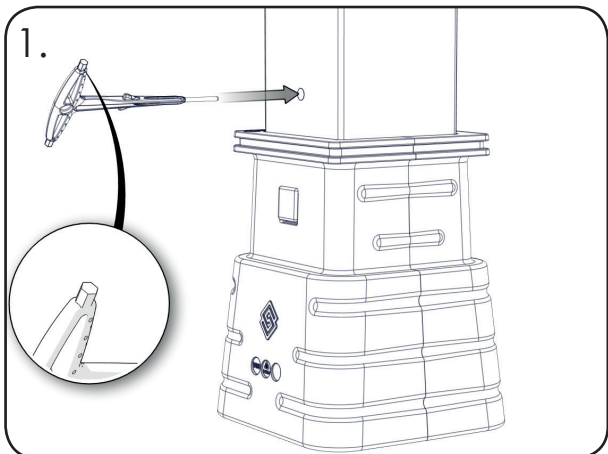

Remove the key hole plug by following step 1 & 2 of 'Security Hole Plug' instructions. Remove the post (Item 1) from the socket (Item 4) by inserting the supplied socket key into the key track to unlock.

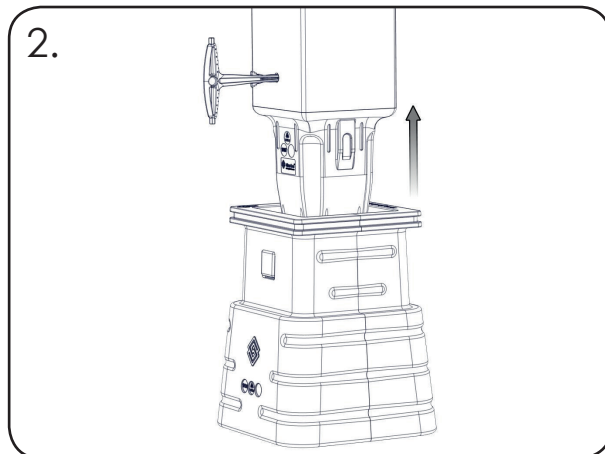

Push the key inwards and lift the post to remove from the socket.

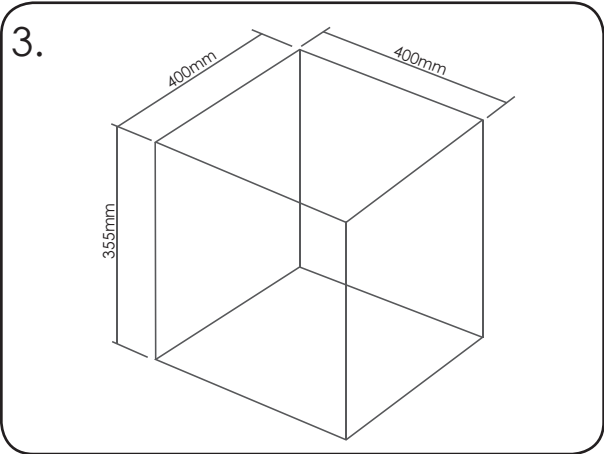

Excavate the hole to the above dimensions and lay gravel or sand in the base of the hole for drainage.
 Note: Take care to avoid buried services when excavating the hole.

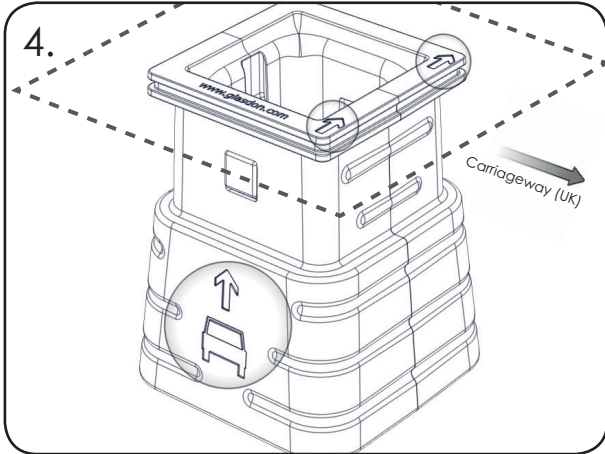

Position the socket into the hole.
 -Ensure the socket is orientated correctly. The socket should be installed with the traffic direction indicators pointing in the direction of traffic on the nearside of the carriageway.

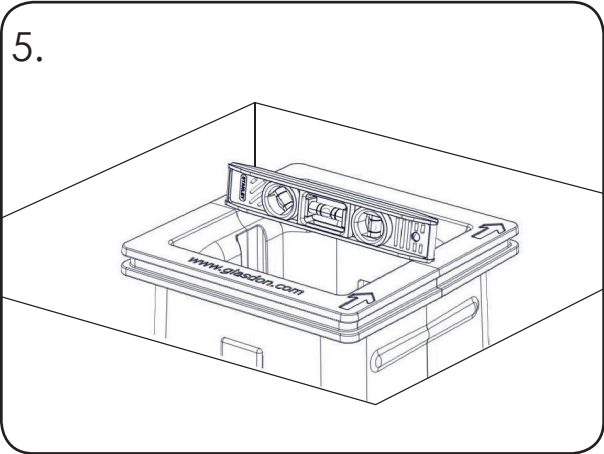

Use a spirit level to ensure the top of the socket is level and flush with the ground. Add/remove gravel as required to level.

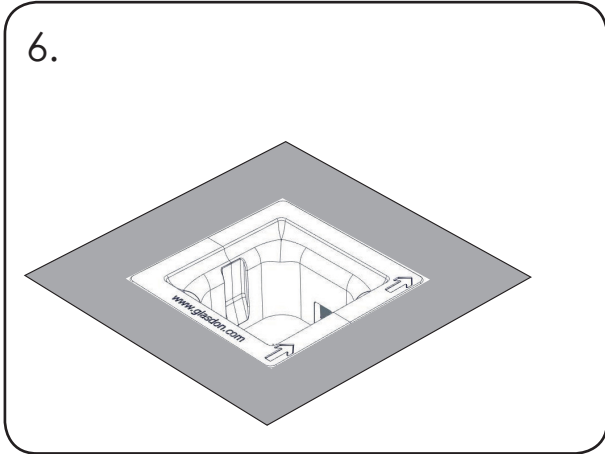

Fill the hole with concrete. Ensure concrete is flush with the top of the socket. Smooth the surface and allow concrete to dry for at least 24 hours. We recommend using quick setting concrete (QC10). Insert the post into the socket to check it is upright and straight.

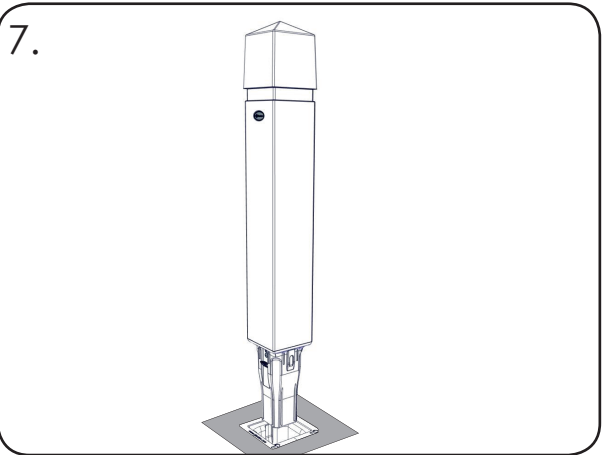

Whilst the concrete sets, insert the post or Blanking Plate into the socket. The post should be installed in the correct orientation according to regulations set out in the TSRGD.

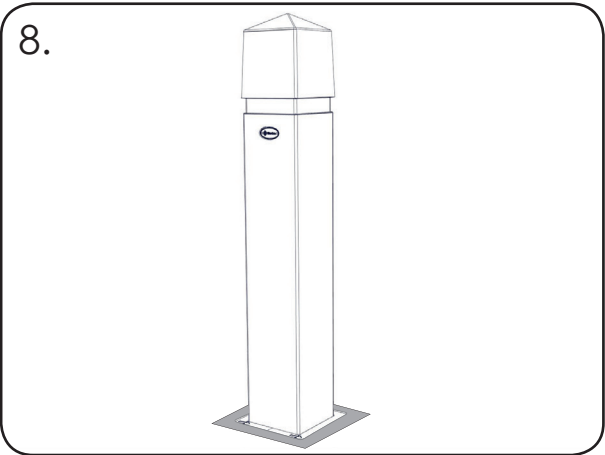

Once the concrete has set ensure the post is locked by attempting to lift from the socket. Insert the security hole plug into the post by following step 3 & 4 of 'Security Hole Plug' instructions.

Glenwood 170 Extended Base Installation Instructions

See our website for a video guide - www.glasdon.com

1. Check for buried services before starting excavations.

2. Mark out and prepare a hole 400mm x 400mm x 315mm deep.

3. Place a small amount of gravel or sand in the base of the prepared hole and position post into the hole. Add/remove gravel as required to help position the post at the correct height.

-Ensure the top of the post stem is level with the ground.

-Ensure the post is vertical with the use of a spirit level.

-Ensure the post is orientated correctly with regard to the retroreflective banding and the site requirements. (i.e. Red reflector faces oncoming traffic on the near-side and white reflector faces on coming traffic on the off-side).

4. Once the post is positioned correctly pour concrete into the prepared hole to the ground level.

5. Should block paving be required reduce the height of the concrete accordingly to allow the paving to be sited at ground level.

4. Ensure the post remains vertical during the concrete setting period. Leave to set.

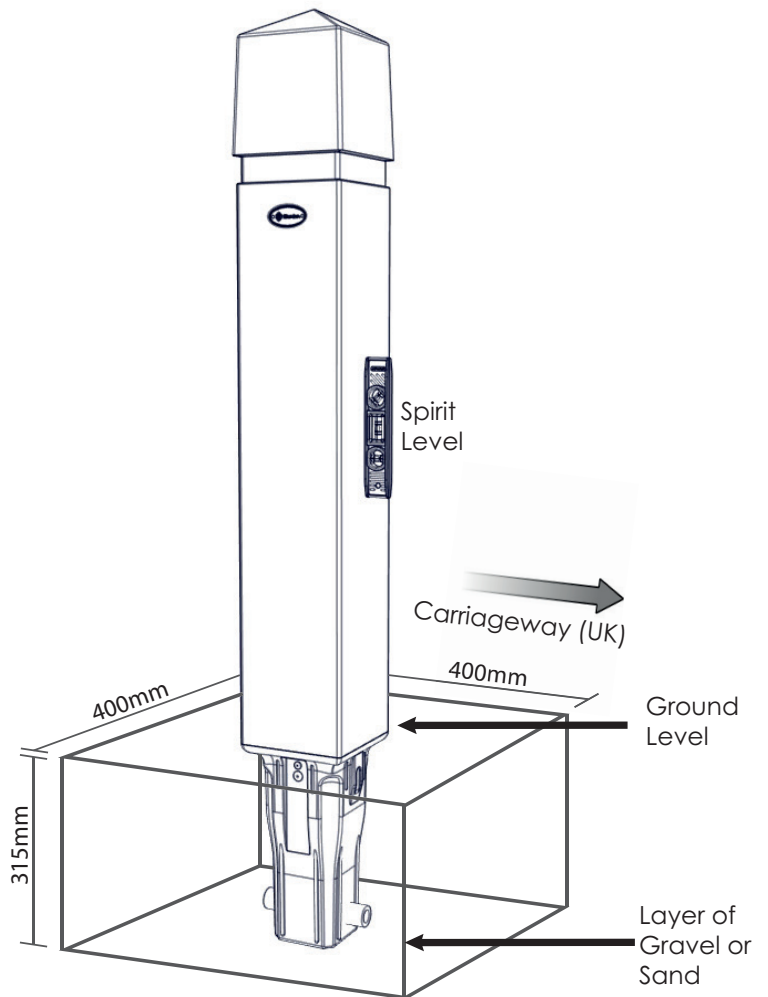

Glenwood 170 Socketed Post Operating Instructions

1.

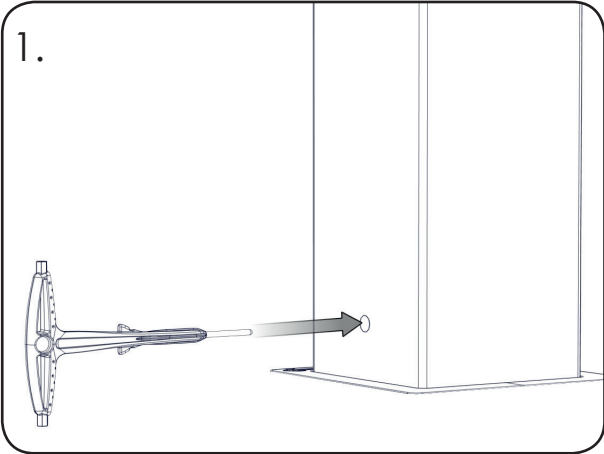

Remove the key hole plug by following step 1 & 2 of 'Security Hole Plug' instructions. To remove the post locate the lock hole and fully insert the key.

2.

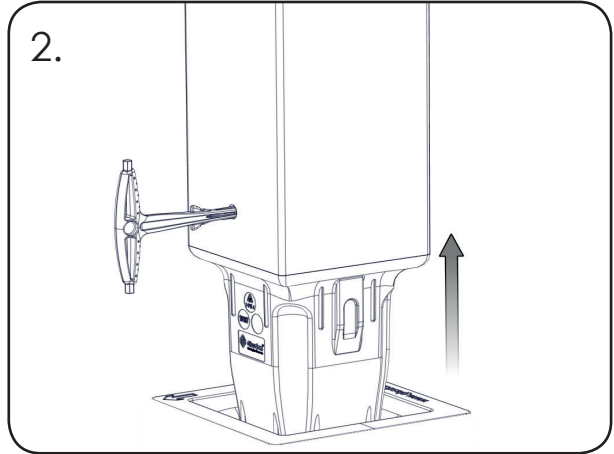

Firmly push the key into the track and lift to remove the post from the socket.

3.

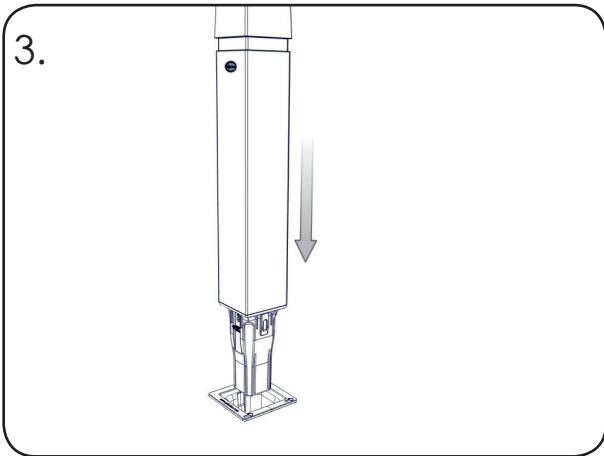

To lock the post in place, drop it into the socket. Ensure the post is orientated correctly with regard to the retroreflective banding and the site requirements (i.e. red reflector faces oncoming traffic on the near side and white reflector faces oncoming traffic on the off-side).

4.

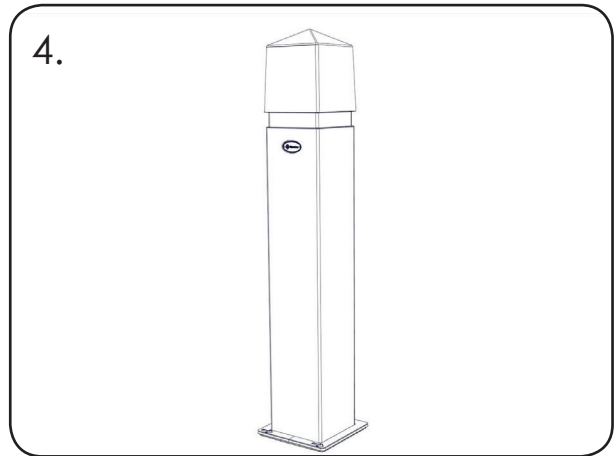

Ensure the post is locked by attempting to lift out. Insert the security hole plug by following step 3 & 4 of 'Security Hole Plug' instructions.

Insert and Remove Optional Blanking/Installation Plates

1.

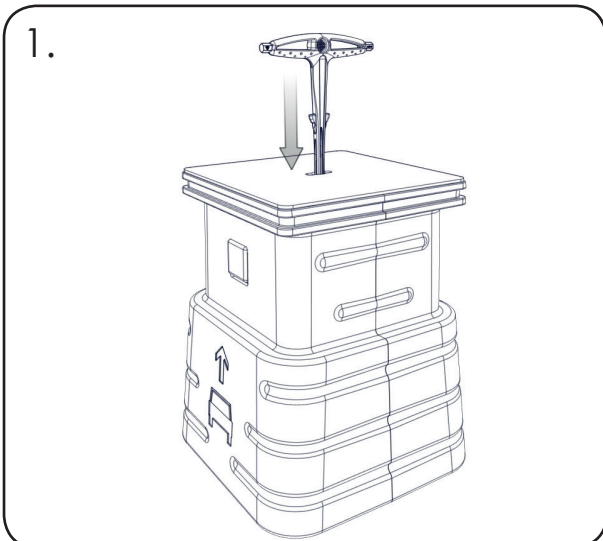

To remove, insert key into the shaped hole in the plate.

2.

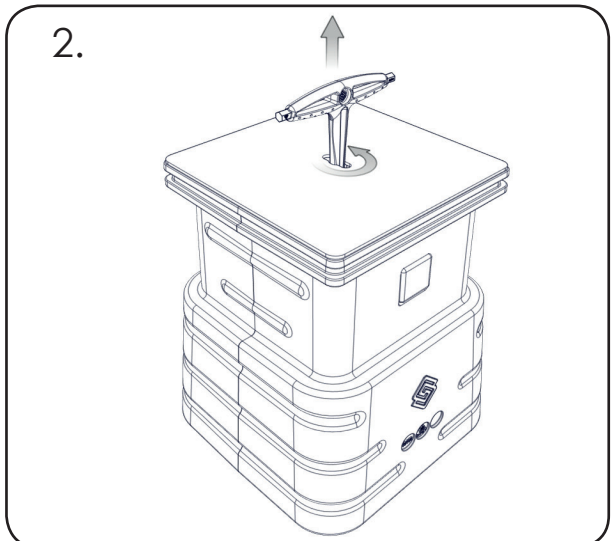

Push down, turn key 45 degrees and lift to remove plate.

IMPORTANT NOTE: PLEASE ENSURE THAT ALL RELEVANT PERSONNEL READ THE POINTS LISTED WITHIN THIS LEAFLET AND THAT A COPY IS GIVEN TO STAFF INVOLVED WITH THE INSTALLATION AND MAINTENANCE OF THIS PRODUCT.
SAFETY NOTE: PLEASE REFER TO 'THE MANUAL HANDLING OPERATIONS REGULATIONS 1992' DURING HANDLING.

 **Glasdon** AND GLENWOOD™ ARE TRADEMARKS OR REGISTERED TRADEMARKS OF GLASDON GROUP OR ITS SUBSIDIARIES IN THE U.K. AND OTHER COUNTRIES

- A planned maintenance schedule or regular inspection is recommended, replacing components as necessary.
- Replacement components are available direct from GLASDON.
- GLASDON cannot be held responsible for claims arising from incorrect installation, unauthorised modifications or misuse of the product.

Stock No. C000/0525 - DWG No. 11B-055-17 Issue 1 - April 2019

© Copyright April 2019

Glasdon UK Ltd reserve the right to alter specifications without prior notice.

 **Glasdon®**
Glasdon U.K. Limited
Preston New Road
BLACKPOOL
Lancashire
FY4 4UL
Tel: (01253) 600410
Fax: (01253) 792558
e-mail: sales@glasdon-uk.co.uk
web: www.glasdon.com